

ART 550+



Specifications

- Fanuc/ Mitsubishi/Siemens Controllers
- LM Guideways (THK Make)
- C3 class ball screws(THK/Rexroth Make)
- Direct coupled servomotors to the ball screws.
- High performance digital motors for spindle and axes
- Absolute encoders for all the Axes
- Fast Electro-mechanical Turret
- Machine Guard with efficient coolant and chip flow
- Centralized Lubrication system
- Coolant System
- TPM Friendly Machines
- 3-jaw Chuck

INQUIRY NOW

sicorporation.rajkot@gmail.com
76000 30037 / 76000 97202

WWW.SICORPORATION.IN

CAPACITY DIAGRAM

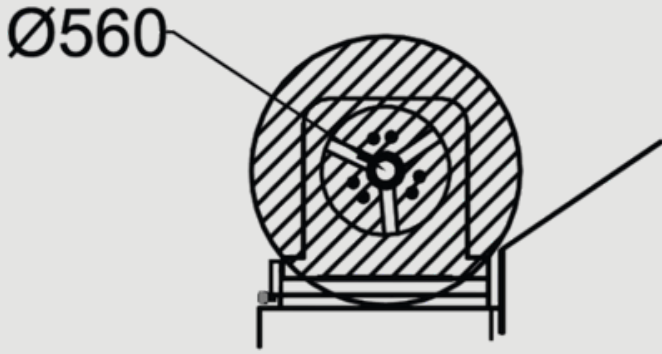

SWING OVER BED

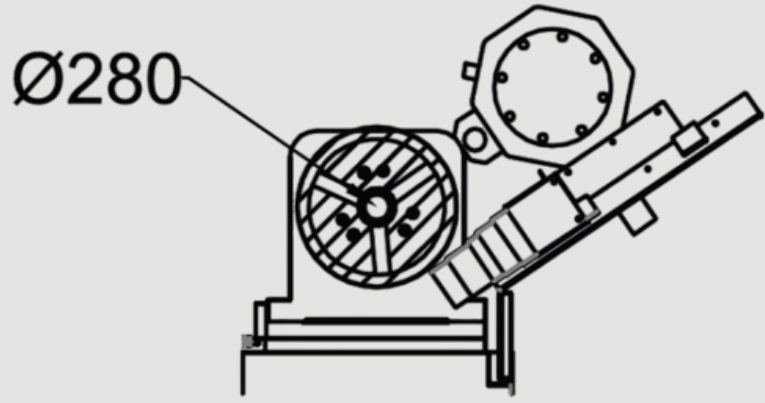

SWING OVER CARRIAGE

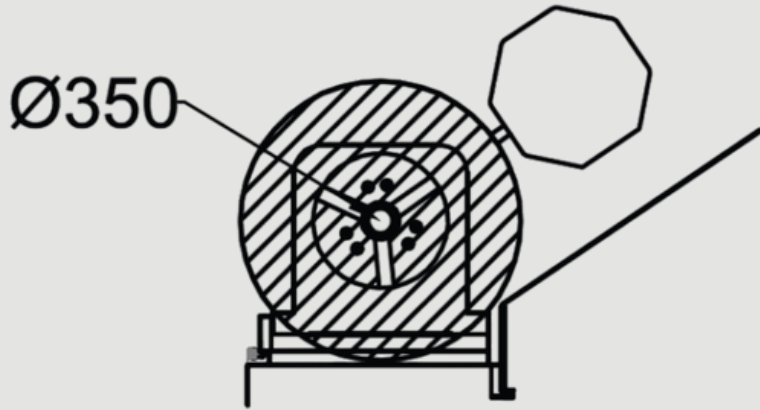

MAXIMUM TURNING DIA

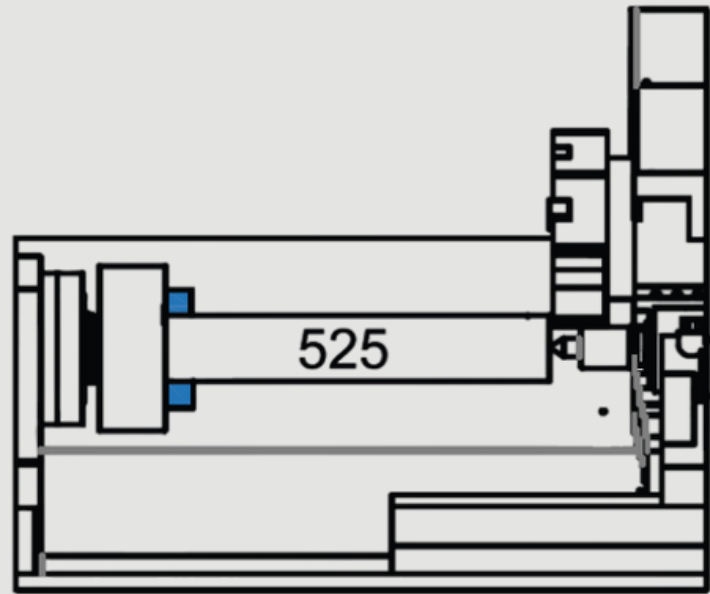

MAX TURNING LENGTH

POWER DIAGRAM

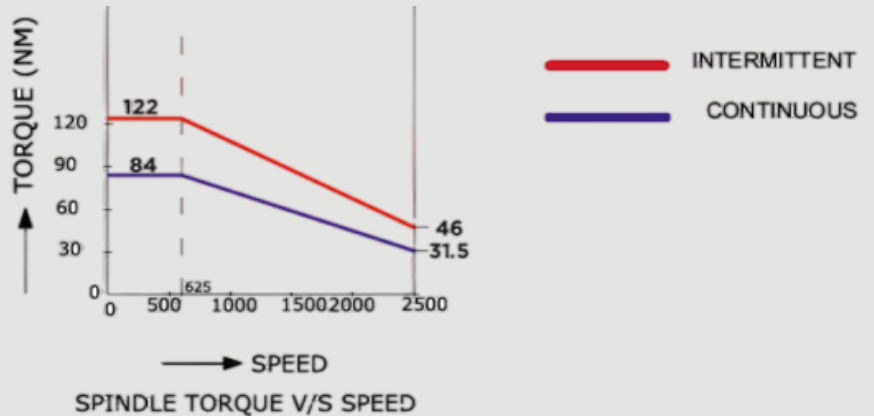
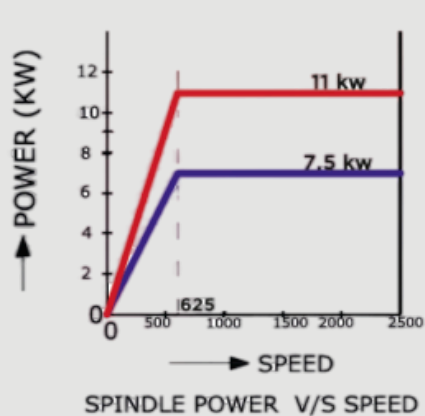

TECHNICAL SPECIFICATION

Details	Units	Specifications
BED TYPE		True Slant Bed 34°
MAX. SWING DIA OVER BED	MM	560
MAX. SWING DIA OVER CARRIAGE	MM	280
CHUCK SIZE	MM	200
MAX. TURNING DIA	MM	350
MAX. TURNING LENGTH WITH CHUCK	MM	525
MAX. TURNING LENGTH BTW. CENTRE	MM	575
SLIDES		---
X-AXIS TRAVEL / Z-AXIS TRAVEL	MM	250/550
RAPID	M/MIN	25
BALL SCREW	MM	32x10 c3 class
X/Z LM GUIDEWAYS	MM	(Roller Type)
MAIN SPINDLE		Cartridge Type
SPINDLE MOTOR POWER	KW	7.5/11
SPINDLE BORE/ DRAW BAR CAPACITY	MM	63/50
SPINDLE NOSE	ISO	A 2-6
SPINDLE SPEED RANGE	RPM	50-2500
FULL POWER AVAILABILITY	RPM	625 Rpm Onwards
TOOLING TYPE		BTP-80
NO. OF TOOLS	NOS.	8
MAX BORING BAR CAPACITY / TOOL SHANK	MM	40/ 25X25
TAIL STOCK		MT-4
QUILL DIA/ QUILL STROKE	MM	80/110
QUILL BODY MOVEMENT	MM	500
ACCURACY		---
POSITIONING ACCURACY	MM	±0.007
REPEATABILITY	MM	±0.005
MACHINE WEIGHT (APPROX)	KG	4300
MACHINE DIMENSIONS (LXWXH)	MM	2540X1640X2060

- DEPENDS UPON CLAMPING ARRANGEMENT, TOOLING AND JOB.
- BAR CAPACITY- DEPENDS ON APPROPRIATE CLAMPING BETWEEN CHUCK AND CYLINDER.